

## Influence of the Printing Parameters on the Properties of PLA Parts Produced by Fused Filament Fabrication

Rasha Alkabbanie<sup>1</sup> & Qusay Awwad<sup>2</sup> & Mohallab Al- Dawood<sup>3</sup>

<sup>1&2</sup>Mechatronics Engineering Department, Faculty of Engineering, Tishk International University, Erbil, Iraq

<sup>3</sup>Mechanical Design Engineering Department, Faculty of Engineering, Damascus University, Damascus, Syria

Correspondence: Rasha Alkabbanie, Tishk International University, Erbil, Iraq.

Email: rasha.alkabbanie@tiu.edu.iq

Doi: 10.23918/eajse.v6i2p131

**Abstract:** This research aims at specifying the effects of some 3d printing parameters (the layer height, the feed rate, the extrusion temperature, and the raster angle) on some surface and mechanical properties (the ultimate tensile strength, the hardness, and the surface roughness) of PLA specimens produced by 3d printing. The paper starts with brief information about the material used (PLA), then it is followed by a short introduction about the experimental work. The influence of each parameter was specified for each property. It was found that the ultimate tensile strength increases by decreasing the layer height, increasing the feed rate, increasing the extrusion temperature, and using a smaller raster angle. The hardness increases by decreasing the layer height, increasing the feed rate, increasing the extrusion temperature, and using a larger raster angle. The surface roughness increases by increasing the layer height, the feed rate, the extrusion temperature, and using a larger raster angle.

**Keywords:** 3d Printing, Additive Manufacturing, Fused Filament Fabrication, Ultimate Tensile Strength, Hardness, Surface Roughness

### 1. Introduction

Additive manufacturing (AM) is a process where the object is produced directly from a computer model by selectively sintering, solidating, and depositing a layer one after another (Horn & Harrysson, 2012). AM enabled manufacturers fabricate complex components, as single-unit parts. This was impossible with traditional fabrication methodologies (Adekanye et al., 2017). Using AM helps to produce customized and even impossible to – manufacture parts right where they will be utilized. Fields where AM is used the most are: medical, automotive, and aerospace industries. It has been also used in other areas such as: food, clothing, and metal fabrication (Kalva, 2015).

The AM is mainly used for the following aims (Doubrovski et al., 2011):

1. Part consolidation: components with air ducts in Boeing, composed of 15 pieces, are produced as one complex part using AM.

Received: October 17, 2020

Accepted: December 5, 2020

Alkabbanie, R., & Awwad, Q., & Al- Dawood, M. (2020). Influence of the Printing Parameters on the Properties of PLA Parts Produced by Fused Filament Fabrication. *Eurasian Journal of Science & Engineering*, 6(2), 131-140.

2. Functional customization: such as producing human implants which are perfect-fit.
3. Weight reduction: as it is increasing the freedom of the design's geometry.

In the aerospace area, NASA manufactured 70 of the parts that form the rover by using AM. Whereas, in the architecture field, the poly-jet 3d printing technique is used to get fine smooth complex geometry models (Ramya & Vanapalli, 2016).

Despite all the above-mentioned advantages of AM, this method is not mature enough to be used in the real industrial world. AM has many challenges and flaws that need to be figured out. Among them are the followings: produced object size limitation, overhang surface formation, anisotropic mechanical properties, low dimensional accuracy, stringing, gabs formation in the upper layers, layers incorrect arrangement, and material use limitation (Abdulhameed et al., 2019).

Accompaniment of 3d scanning and AM technologies brought new opportunities to the healthcare implant industries with which prostheticers could fabricate limbs, artificial hips, or dental implants that precisely fit the individuals (Álvarez, 2014). Additionally, AM affects the logistics and supply chain area by reducing the number of products stored in the warehouses by enabling on-demand production (Raji, 2017).

The AM includes a lot of technologies, for example (Manufacturing, n.d.):

- Stereolithography Apparatus: in this technique a laser beam selectively cures liquid resin.
- Powder Bed Fusion: a laser of electronic beam selectively sinters powdered material.
- Sheet Lamination: in this method, an ultrasonic welding is utilized to stack laminated layers together.
- Fused Filamin Fabrication: this technology is explained in detail in chapter ..... of this paper.
- Hybrid AM: in this technology, the traditional manufacturing techniques, like milling and CNC, are combined with AM process in a single machine.

A wide variety of materials are being used by the AM technologies. The following table shows the materials commonly used in the AM (MakerBot, 2020).

Table 1: Materials commonly used in the AM

PLA (polylactic acid)	Concept prototypes.
PETG's (glycol-modified polyethylene terephthalate)	Liquid containers and bottles.
ABS (acrylonitrile butadiene styrene)	Functional prototypes, manufacturing tools.
ASA (acrylonitrile styrene acrylate)	Ideal for equipment exposed to sunlight and rain over long periods of time – such as products for the agriculture, transportation, and power and utility industries.
Nylon	Replacement Parts, gears.
PC-ABS	Automotive industry.
PC-ABS FR	Automotive, railway, and aerospace industries.

There are many 3d-printing parameters that can be manipulated to optimize the properties of the printed parts, including but not limited to the followings (Fernandes et al., 2018):

- Infill density: the percentage of material forming the interior volume of the part regarding the total volume.
- Raster Angle: the angle in which the strands of the material is aligned within the printed part.
- Layer thickness: the height measure of each material addition.
- Extrusion temperature: the temperature of the material when extruded from the nozzle.

## 2. Methodology

### 2.1 The Experiments

This research aims at providing better understanding of the influence of the printing parameters of the mechanical and surface characterization. Among the wide variety of the tests, the following were chosen:

- The Tensile Test.
- Shore Hardness Test.
- Surface Roughness.

Figure (1) illustrates the test specimen of the tensile test while Figure (2) shows the specimen of the hardness test, and in the Figure (3), the surface roughness specimen is shown.

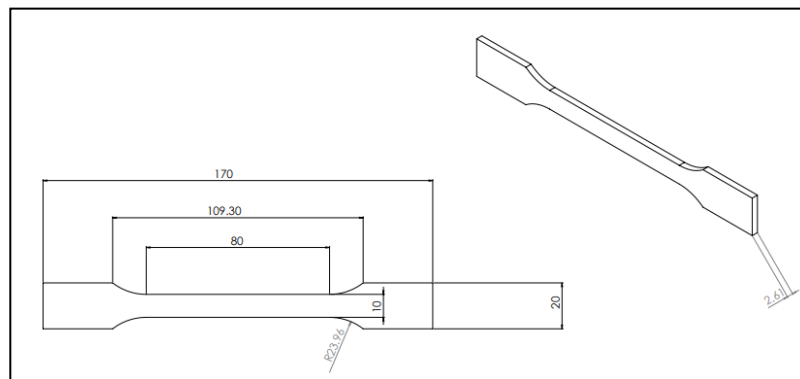

Figure 1: The specimen of the Tensile Test

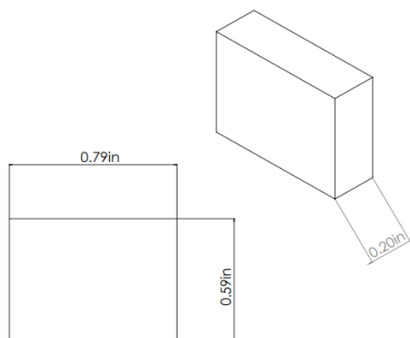

Figure 2: The specimen of the hardness test

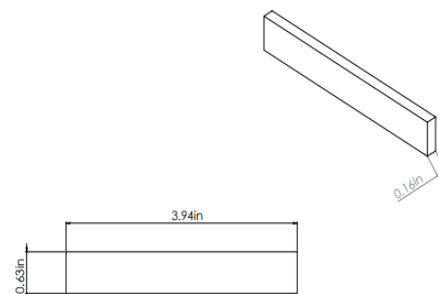

Figure 3: The specimen of the surface roughness test

## 2.2 The 3d Printing Technology; Fused Deposition Modeling (FDM)

In this technique, the material is deposited through a nozzle fed with filament from a coil. The nozzle moves according to the x and y predetermined coordinates. The build platform moves down gradually in the z direction as per the specified layer thickness.

The following figure illustrates the FDM process.

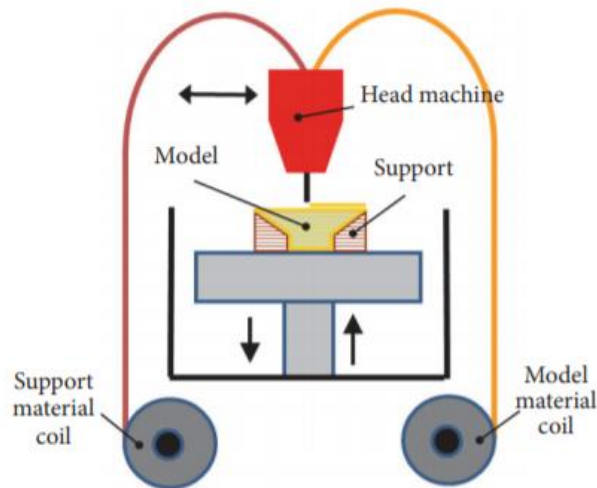

Figure 4: FDM process (Jimenez et al., 2019)

## 2.3 The 3d Printer

The “Up Box” 3d printer was used to 3d print the specimen.



Figure 5: The 3d Printer

## 2.4 Material

Since that many researchers studied the effect of 3d printing parameters on the mechanical properties of the ABS, and only few had dealt with PLA, it was decided to choose PLA to be the subject of this research.

The following table illustrates the specifications of the PLA used for printing the specimen:

Table 2: The properties of PLA (Simplyfy3d, 2020)

Property	Value
Ultimate Strength	65MPa
Stiffness	7.5/ 10
Maximum Service Temperature	52°C
Durability	4/ 10
Coefficient of Thermal Expansion	68µm/m-°C

PLA is a biodegradable polymer extracted from renewable sources such as corn starch. Therefore, PLA is utilized to produce medical implants which are designed to degrade without causing any harm to be placed back by growing tissues. The PLA 3d-printing process is also characterized by the absence of toxic gases produced during the melting and deposition stages and its low temperature of glass transition. The PLA material softens at relatively low temperature (60-65 °C ) and thus it can't be used in heated environments, however, it means that this material has enough time to get rid of the internal stresses when cooling. This indicates that there is no need to preheat the platform or to use special adhesives (Bates- Green & Howie, 2017).

## 2.5 The Tests

### 2.5.1 The Tensile Test

The tensile tests were conducted at the Mechanical Engineering labs of Damascus University. The specimens were printed as per the standard ISO 527-2.

### 2.5.2 The Hardness Test

The hardness test was conducted according to the international standard "ASTM D224". All specimens were subjected to shore durometer test. A greater resistance to indentation, which means the harder the material results the higher shore number and the vice versa. In this test, a force is exerted to the material through a presser foot that leads to an indentation in the specimen, the durometer measures the depth of this indentation. In this experiment, the specimens' surfaces must be parallel to the surface of the test bed.

### 2.5.3 The Surface Roughness Test

The surface roughness is one of the surface texture elements. It is measured by the deviations in the direction of the normal vector of a real surface from its ideal form. The larger the deviation, the rougher is the surface. In this research, the surface roughness is measured by "Ra" which means, as described in the international standard ASME B46.1, the arithmetic average of the profile height deviation values from the mean line.

## 3. Results and Discussions

### 3.1 The Layer Height

It was observed that the higher the layer height the lower is the ultimate tensile strength, and the lower

is the hardness the higher is the surface roughness. The Figures (6), (7), and (8) show the relation between the layer height and the ultimate tensile strength, the hardness and the surface roughness respectively.

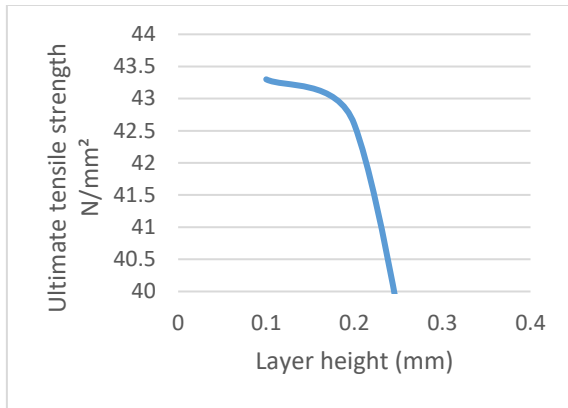

Figure 6: Layer height vs. the ultimate tensile strength

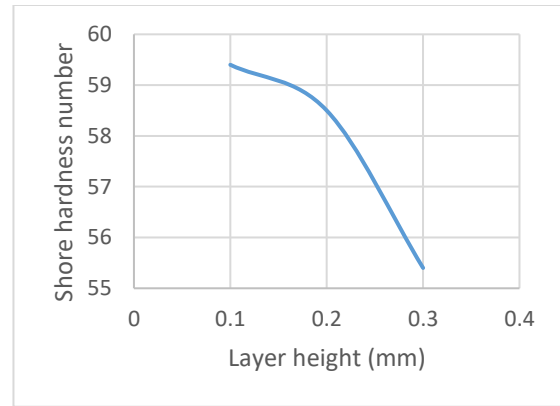

Figure 7: Layer height vs. the Hardness

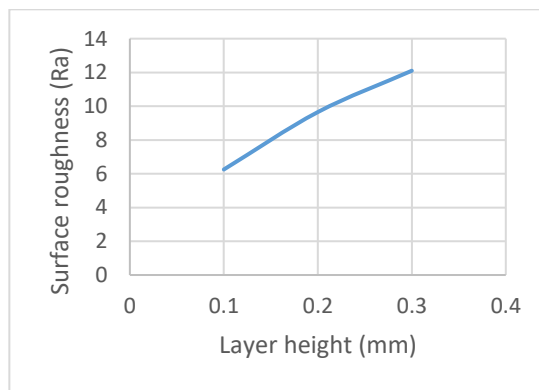

Figure 8: Layer height vs. the surface roughness

And this is since the adhesion between layers becomes stronger when decreasing the layer height. And when the adhesion between the layers is stronger, the flexibility of the specimen decreases.

### 3.2 The Feed Rate

It was realized that when increasing the feed rate, the ultimate tensile strength increases, the hardness increases, and the surface roughness increases as well. The Figures (9), (10), and (11) illustrate the relation between the feed rate and the ultimate tensile strength, the hardness, and the surface roughness respectively.

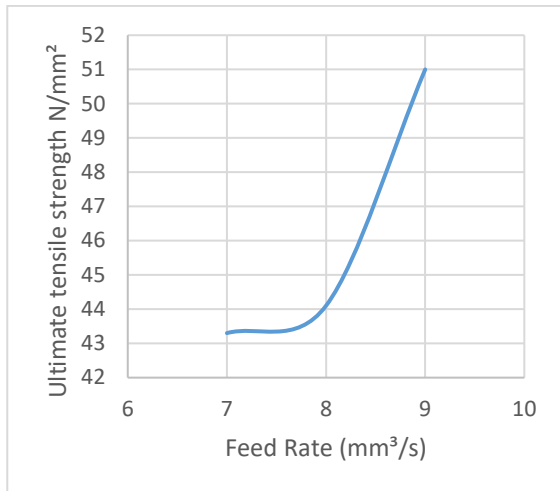

Figure 9: Feed rate vs. the ultimate tensile strength

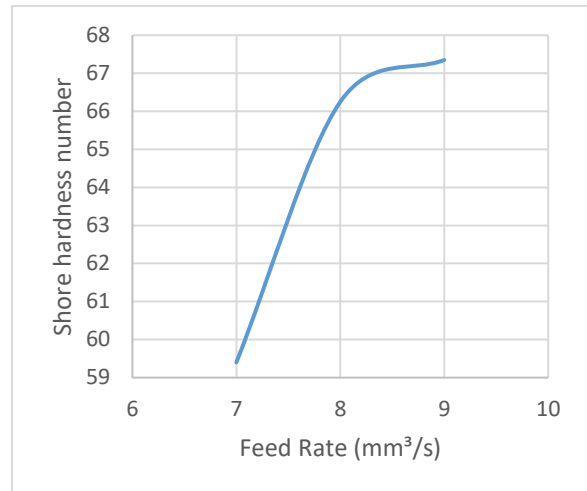

Figure 10: Feed rate vs. the Hardness

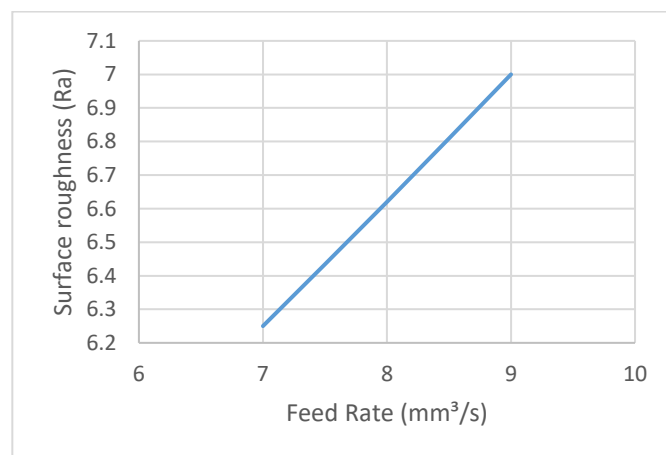

Figure 11: Feed rate vs. the surface roughness

This finding can be explained by the fact that the mechanical properties in the objects enhances when having more amount of material.

### 3.3 The Extrusion Temperature

It was observed that when using a higher extrusion temperature, the ultimate tensile strength increases, also both the hardness and the surface roughness increase as well. The Figures (12), (13), and (14) show the relation between the extrusion temperature and the ultimate tensile strength, the hardness, and the surface roughness, respectively.

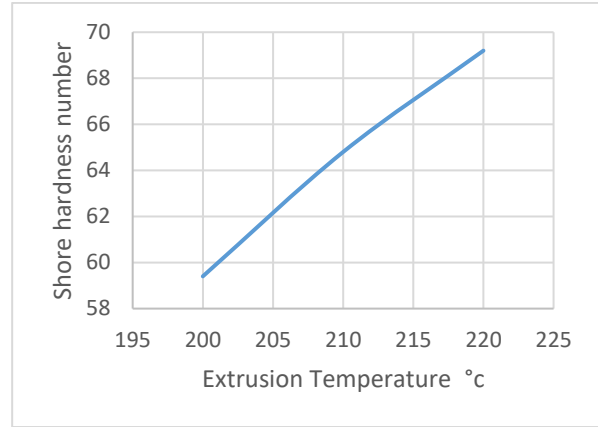
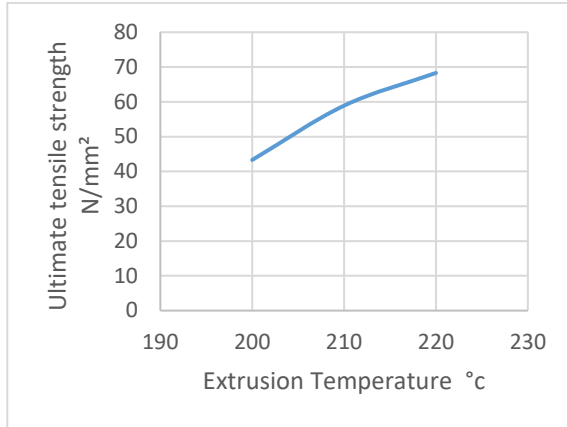

Figure 12: Extrusion temperature vs. the ultimate tensile strength

Figure 13: Extrusion temperature vs. the Hardness

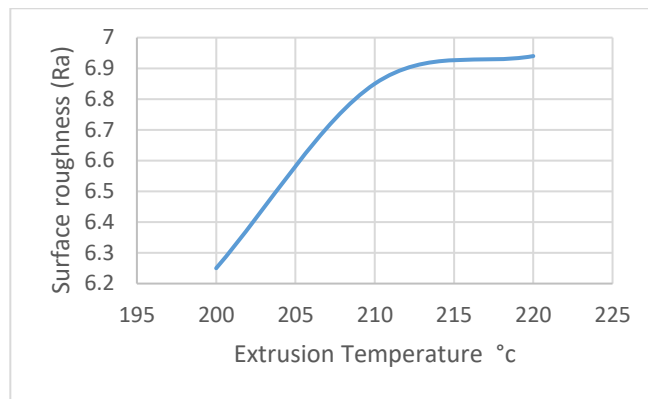

Figure 14: Extrusion temperature vs. the surface roughness

And this can be explained by the fact that when using a higher extrusion temperature, the adhesion increases and at the same time the material becomes less solid.

### 3.4 The Raster Angle

The experimental results indicated that when using a larger raster angle, the ultimate tensile strength decreases, while both the hardness and the surface roughness increase. The Figures (15), (16), and (17) illustrate the relation between the raster angle and the ultimate tensile strength, the hardness, and the surface roughness, respectively.



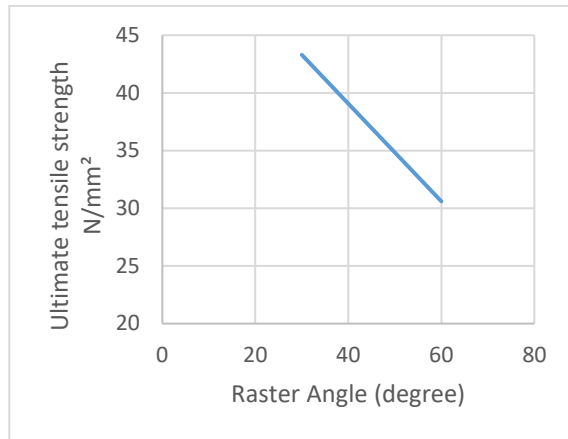

Figure 15: Raster angle vs. the ultimate tensile strength

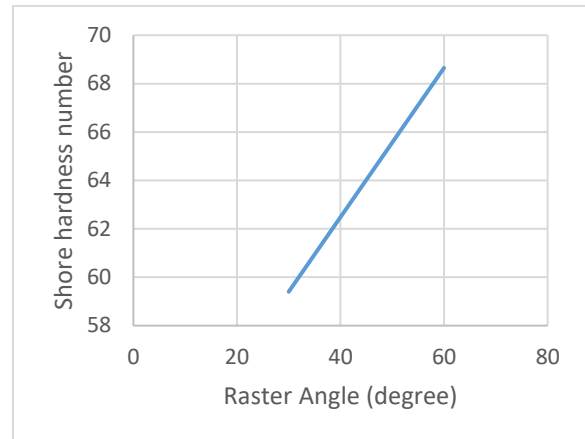

Figure 16: Raster Angle vs. the Hardness

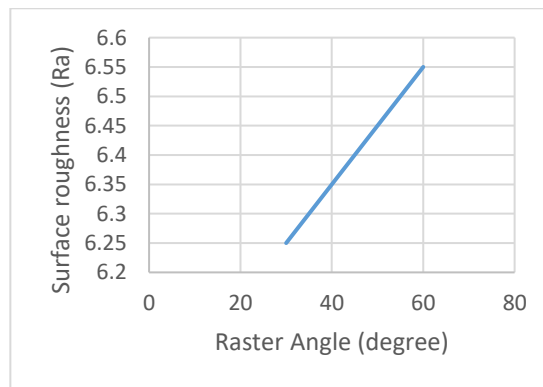

Figure 17: Raster Angle vs. the surface roughness

This is since the stiffness of the structure increases when using smaller raster angles.

## 5. Conclusions

1. The ultimate tensile strength decreases by increasing the layer height.
2. The hardness decreases by increasing the layer height.
3. The surface roughness increases by increasing the layer height.
4. The ultimate tensile strength increases by increasing the feed rate.
5. The hardness increases by increasing the feed rate.
6. The surface roughness increases by increasing the feed rate.
7. The ultimate tensile strength increases by increasing the extrusion temperature.
8. The hardness increases by increasing the extrusion temperature.
9. The surface roughness increases by increasing the extrusion temperature.
10. The ultimate tensile strength decreases when using a larger raster angle.
11. The hardness increases when using a larger raster angle.
12. The surface roughness increases when using a larger raster angle.

## References

- Abdulhameed, O., Al-Ahmari, A., Ameen, W., & Mian, S. H. (2019). Additive manufacturing: Challenges, trends, and applications. *Advances in Mechanical Engineering*, 11(2), 1687814018822880.
- Adekanye, S. A., Mahamood, R. M., Akinlabi, E. T., & Owolabi, M. G. (2017). Additive manufacturing: the future of manufacturing. *Additive Manufacturing*, 709, 715.
- Álvarez, L. H. (2014). White Paper 3d printing. Retrieved from atos.net: <https://atos.net/wp-content/uploads/2016/06/01052014-AscentWhitePaper-3dPrinting-1.pdf>
- Bates-Green, K., & Howie, T. (2017). Materials for 3D printing by fused deposition. *Technical Education in Additive Manufacturing and Materials*, 1-21.
- Dobrovski, Z., Verlinden, J. C., & Geraedts, J. M. (2011, January). Optimal design for additive manufacturing: opportunities and challenges. In *International Design Engineering Technical Conferences and Computers and Information in Engineering Conference* (Vol. 54860, pp. 635-646).
- Fernandes, J., Deus, A. M., Reis, L., Vaz, M. F., & Leite, M. (2018). Study of the influence of 3D printing parameters on the mechanical properties of PLA.
- Horn, T. J., & Harrysson, O. L. (2012). Overview of current additive manufacturing technologies and selected applications. *Science Progress*, 95(3), 255-282.
- Jiménez, M., Romero, L., Domínguez, I. A., Espinosa, M. D. M., & Domínguez, M. (2019). Additive manufacturing technologies: An overview about 3D printing methods and future prospects. *Complexity*, 2019.
- Kalva, R. S. (2015). 3D printing—the future of manufacturing (The next industrial revolution). *International Journal of Innovations in Engineering and Technology*, 5(1), 184-190.
- MakerBot. (2020). 2020 Guide to 3D printing materials. Retrieved from <https://cdn.cnetcontent.com/https://cdn.cnetcontent.com/syndication/mediaserverredirect/e6b5204e10f48834b7bc52e4ebb89b69/original.pdf>
- Manufacturing, A. (n.d.). Retrieved from [https://www.additivemanufacturing.media/https://www.additivemanufacturing.media/cdn/cms/7\\_families\\_print\\_version.pdf](https://www.additivemanufacturing.media/https://www.additivemanufacturing.media/cdn/cms/7_families_print_version.pdf)
- Raji, I. O. (2017). 3D Printing Technology—Applications, Benefits and Areas of Opportunity in Nigeria. *International Journal of Advanced Academic Research Sciences, Technology & Engineering*, 3, 21-30.
- Ramya, A., & Vanapalli, S. L. (2016). 3D printing technologies in various applications. *International Journal of Mechanical Engineering and Technology*, 7(3), 396-409.
- Simplyfy3d. (2020). Filament Properties Table. Retrieved from [simplify3d.com: https://www.simplify3d.com/support/materials-guide/properties-table/](https://www.simplify3d.com/support/materials-guide/properties-table/)